

INSTRUCTIONS

#12-271 Screed Sawing Handles

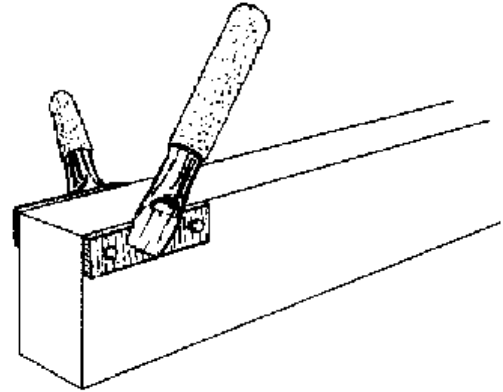

ASSEMBLY

1. Drill two holes $9/32$ " in diameter through both walls of screed at each end (4 holes total) as shown below.

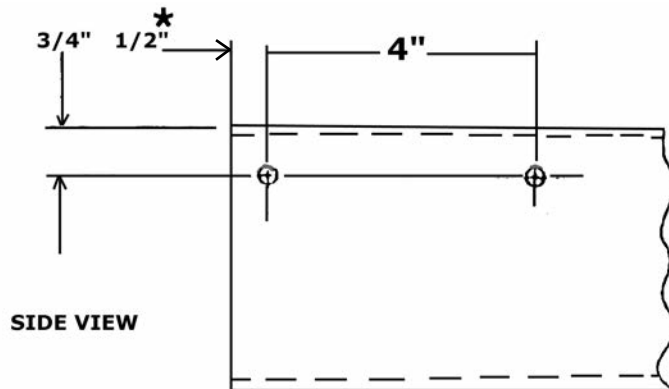

* This dimension locates handles flush with the end of the screed. Handles may be mounted inboard if so desired.

2. Fasten two saw handles to each end of screed using the four $1/4$ " x $2 1/2$ " long bolts and elastic stop nuts as shown at right.

TOP VIEW

